

Airtime™ Wall Rail - WRC300* | Main Components

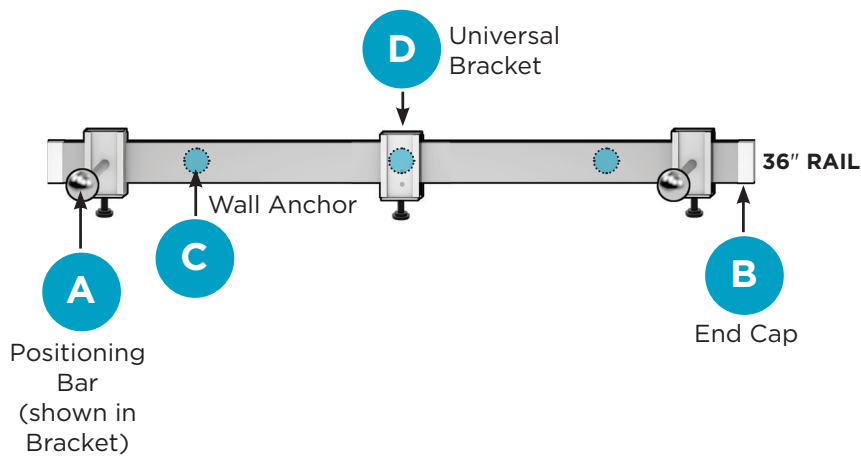

Included with WRC300:

- 1 - 36" Rail
- 2 - Positioning Bars** (A)
- 2 - End Caps (B)
- 3 - Wall Anchors (C)
- 3 - Universal Brackets (D)

*Used to mount one Airtime Control Unit & two flexible endoscopes.

**Positioning bars used to hold scopes.

Airtime™ Wall Rail - WRC500* | Main Components

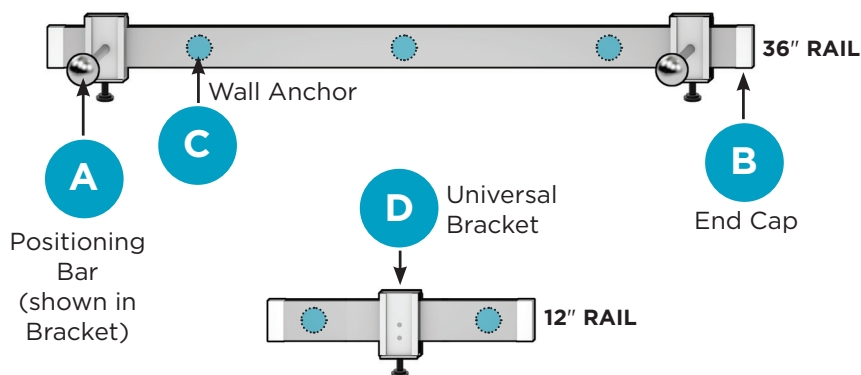

Included with WRC500:

- 3 - 36" Rails
- 1 - 12" Rail
- 6 - Positioning Bars** (A)
- 8 - End Caps (B)
- 11 - Wall Anchors (C)
- 7 - Universal Brackets (D)

*Used to mount one Airtime Control Unit & two flexible endoscopes. Includes height reduction system.

**Positioning bars used to hold scopes and for height reduction.

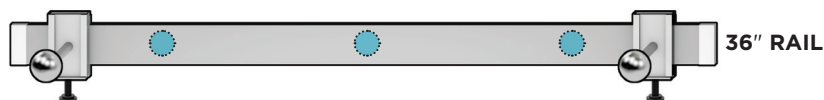
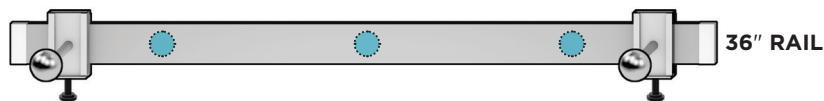

See next page for WRC100, WRC200 Diagrams.

Airtime™ Wall Rail - WRC100* | Main Components

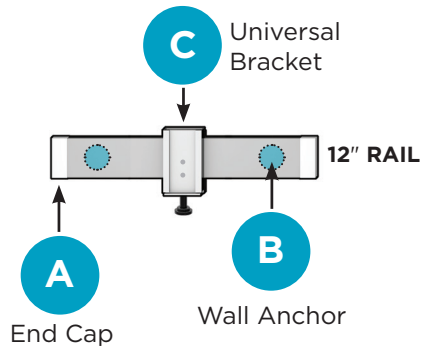

Included with WRC100:

- 1 - 12" Rail
- 2 - End Caps (A)
- 2 - Wall Anchors (B)
- 1 - Universal Bracket (C)

*Used to mount one Airtime Control Unit.

Airtime™ Wall Rail - WRC200* | Main Components

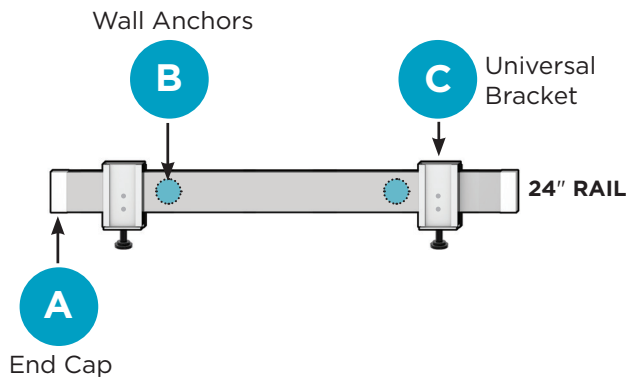

Included with WRC200:

- 1 - 24" Rail
- 2 - End Caps (A)
- 2 - Wall Anchors (B)
- 2 - Universal Brackets (C)

*Used to mount two Airtime Control Units.

WALL RAIL REFERENCE TABLE

SKU	DESCRIPTION	INCLUDED RAILS	POSITIONING BARS	END CAPS	WALL ANCHORS	UNIVERSAL BRACKETS
WRC100	Airtime™ 12" Wall Rail System, used to hold one Airtime Control Unit.	1 - 12"	-	2	2	1
WRC200	Airtime™ 24" Wall Rail System, used to hold two Airtime Control Units.	1 - 24"	-	2	2	2
WRC300	Airtime™ 36" Wall Rail System, used to hold one Airtime Control Unit & two flexible endoscopes.	1 - 36"	2	2	3	3
WRC500	Airtime™ Complete Wall Rail System used to hold one Airtime Control Unit & two flexible endoscopes. Includes height reduction system.	1 - 12" 3 - 36"	6	8	11	7

See next page for information about the Height Reduction System.

Wall Rail Positioning Bars Used for Height Reduction. (WRC500 shown here)

All Positioning Bars are attached to Universal Brackets that can slide into any position on the Wall Rail. Once the Bracket is moved into a desired position, tighten the screw at the bottom to hold it in place. In this diagram the Positioning Bars are adjusting the height of a long insertion tube.

The Height Reduction System enables you to install the Wall Rail at a comfortable working height while ensuring that sensitive equipment will be kept a safe distance from the floor.

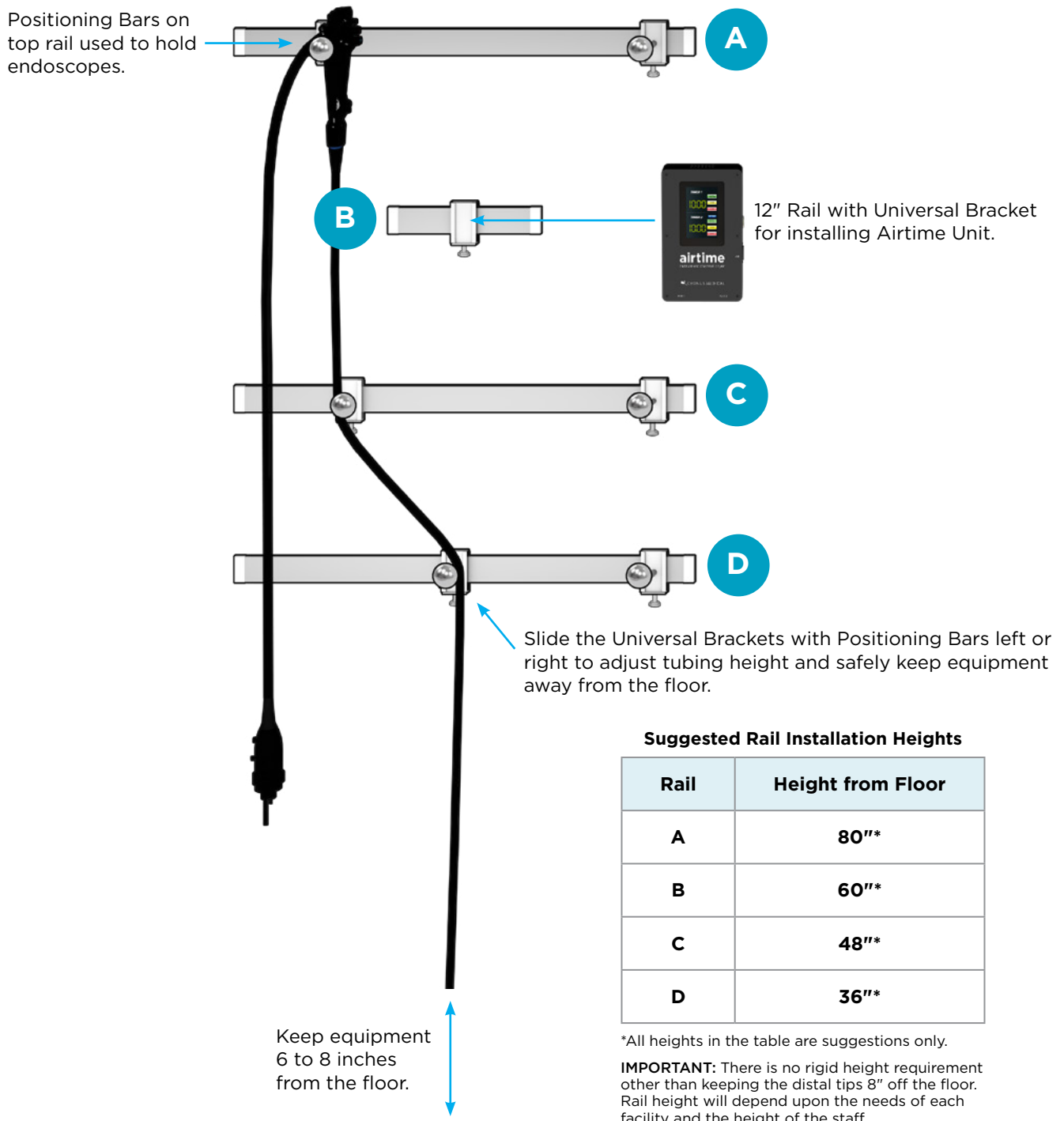

Airtime™ IV Pole Set - IV500 | Assembly Instructions

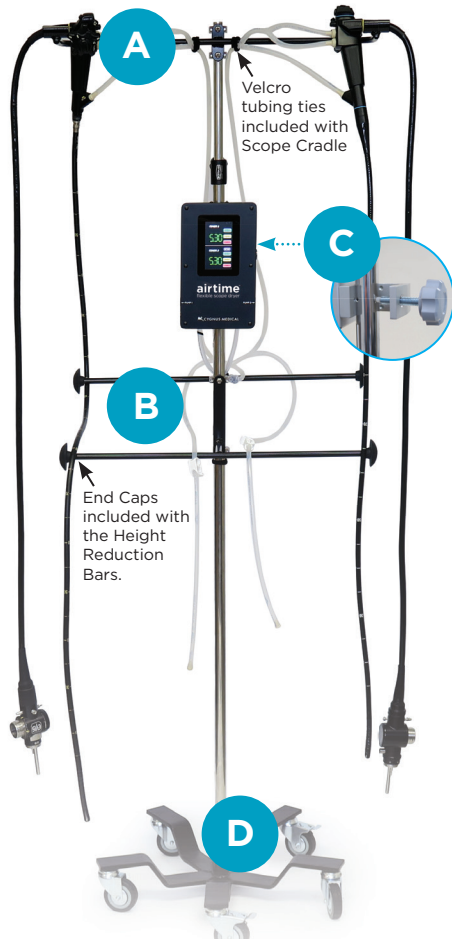

A. Scope Cradle



B. Height Reduction Bars

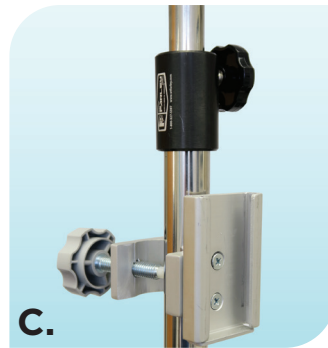

C. Unit Mounting Bracket

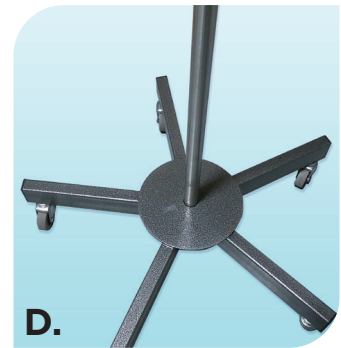

D. IV Pole and Base

Parts Included with IV500:

- One Scope Cradle 27"
- Two Height Reduction Bars 26"
- One Unit Mounting Bracket
- One IV Pole with Base
- One Package of Threadlocker

Tools Needed for Assembly:

- 9/16" Flat Wrench
- 3/16" Allen Wrench

INSTRUCTIONS

Assemble the IV Pole:

1. Remove all packing material and unscrew the Bolt and Washer from the bottom of the IV Pole.
2. Insert the IV Pole into the opening on the Base top.
3. Apply a generous amount of Threadlocker to the threads of the Bolt that you removed.
4. Place the Washer on the Bolt.
5. From the underside of the Base, insert the Bolt through the opening, into the IV Pole, and tighten.
6. Let the IV Pole stand for 4 to 6 hours so the Threadlocker can completely set up.

Add the Airtime Installation Components:

7. Add the Scope Cradle, Height Reduction Bars and Unit Mounting Bracket. **See Page 2 for detailed instructions.**

Airtime™ IV Pole Set - IV500 | Component Assembly Instructions

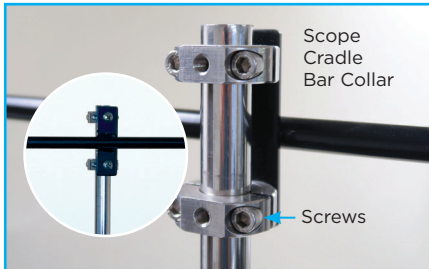
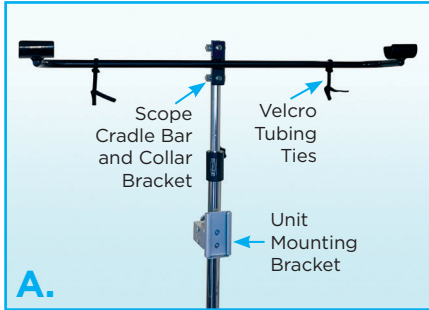

Scope Cradle Bar Install

A. Scope Cradle

Parts: 1 Scope Cradle Bar, 1 Collar Bracket, 2 Velcro Tubing Ties, 4 Screws

1. The Scope Cradle is mounted approximately 1" below the top of the IV Pole.
2. Position the Scope Cradle Bar and Collar Bracket around the IV Pole.
3. Align the Scope Cradle Bar Collar holes and collar bracket holes and insert the four screws. Use a 3/16" Allen Wrench to tighten the screws.

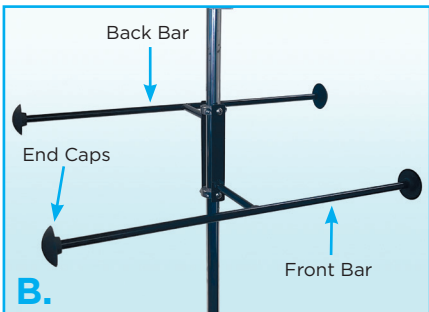

Height Reduction Bar Install

B. Height Reduction Bars

Parts: 2 Bars (Front/Back), 4 End Caps, 4 Screws

1. The Height Reduction Bars are mounted approximately 10" below the Airtime Control Unit.
2. Position the Front and Back bars around the IV Pole. The Back Bar must be higher than the Front Bar.
3. Align the Front Bar holes and Back Bar holes and insert the four screws. Use a 3/16" Allen Wrench to tighten the screws.

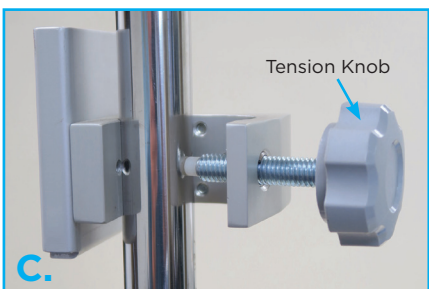

Mounting Bracket Install

C. Airtime Control Unit Mounting Bracket

Parts: 1 Mounting Bracket with Tension Knob

1. Attach mounting bracket by tightening the Tension Knob (screw) against the IV Pole. The height should be approximately 60" from the floor. Slide the Universal Mounting Plate on the back of the Airtime Control Unit into the IV Pole Bracket.